

# compel<sup>®</sup>

## Pivot Frame Conference Table Assembly Instructions



96in Table .....	Page 2
120in Table .....	Page 3
144in Table .....	Page 4

# PIVIT 96" FRAME CONFERENCE TABLE

## PARTS LIST

- 30" SHARED LEG (2)
- 30" END LEG (1)
- FLAT BRACKET (2)
- SURFACE FASTENERS (2)
- BISCUITS (2)
- END SECTION TOP (2)

## REQUIRED TOOLS

- DRILL & PHILLIPS HEAD BIT
- ALLEN WRENCH
- TAPE MEASURE

### IMPORTANT INFORMATION PRIOR TO ASSEMBLY

ASSEMBLE TABLE ON A CARPETED, SOFT, OR PROTECTED AREA WHERE INSTALLTION WILL OCCUR

DO NOT DRAG ASSEMBLED TABLE

2 PEOPLE NEEDED FOR ASSEMBLY. 3 PEOPLE REQUIRED TO TURN TABLE UPRIGHT

## STEP 1

- ASSEMBLE OPEN FRAME LEGS. ATTACH LEG BRACKETS TO LEG FRAME USING FLAT HEAD MACHINE SCREW TO FASTEN. TWO SCREWS PER BRACKET.(IMAGE A)
- USE THE SOCKET HEAD MACHINE SCREWS ON THE SIDE OF THE LEG BRACKET, TIGHTEN. TWO SCREWS PER BRACKET (IMAGE B)
- REPEAT ON THE OPPOSITE SIDE FOR SHARED LEGS
- INSERT GLIDES TO THE BOTTOM OF LEG (IMAGE C)

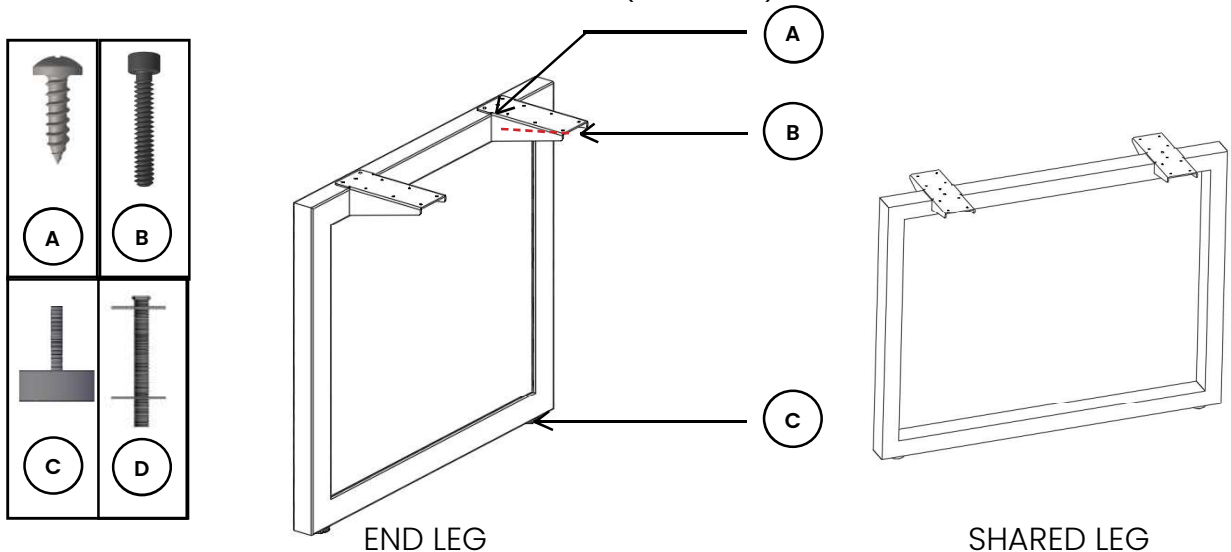

## STEP 2

- LAY TABLE TOPS UPSIDE DOWN CONSECUTIVELY AS SHOWN BELOW IN BOTTOM VIEW REFERENCE. MAKE SURE UNFINISHED EDGES FROM EACH TOP ARE ALIGNED NEXT TO EACHOTHER.
- MEASURE AND POSITION LEGS AS ILLUSTRATED BELOW.
- USING A POWER DRILL, FASTERN THE LEGS ONTO TABLE TOPS BY USING WORK-SURFACES SCREWS
- CONNECT SURFACES WITH FASTENERS (IMAGE D) INTO NOTCHES ON TOPS AND TIGHTEN
- INSTALL FLAT BRACKETS AT SURFACE SEAMS ON TOPS AS SHOWN BELOW

# PIVIT 96" FRAME CONFERENCE TABLE

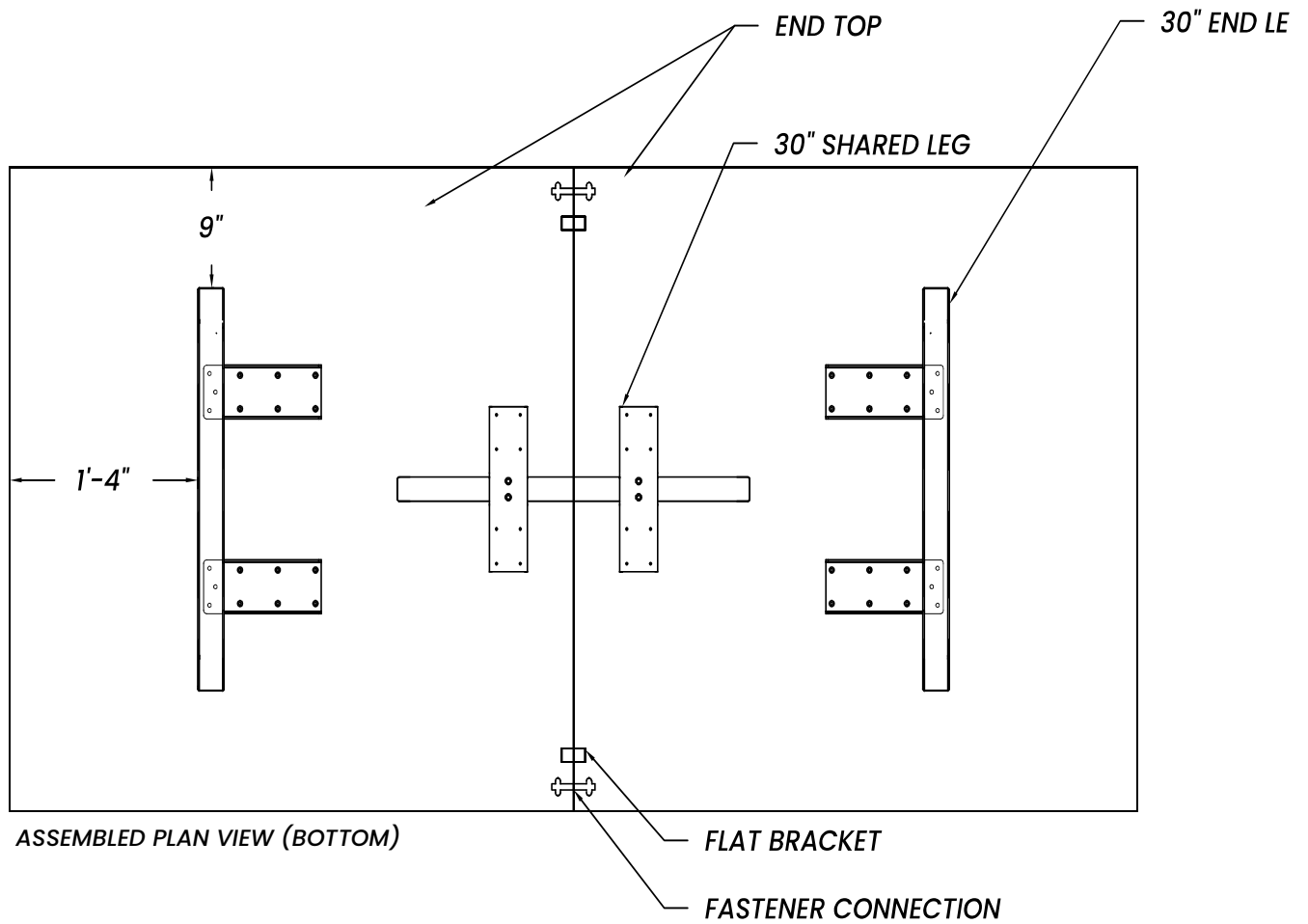

## STEP 3

AFTER ALL COMPONENTS HAVE BEEN FULLY ASSEMBLED AND ATTACHED USE EXTREME CAUTION TO FLIP TABLE RIGHTSIDE UP. 2 OR 3 PEOPLE REQUIRED TO FLIP TABLE.

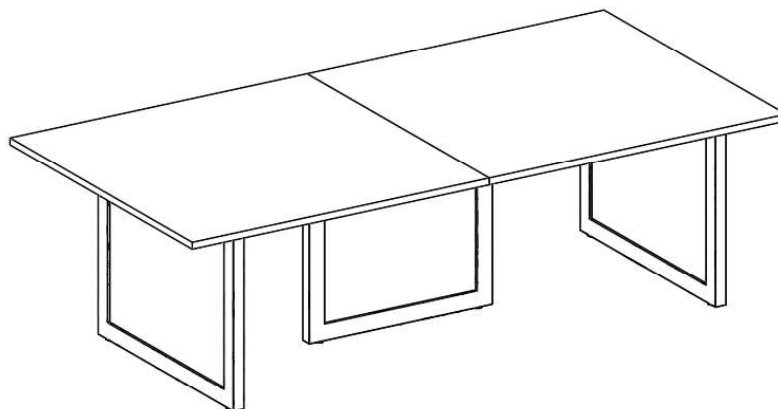

# PIVIT 120" FRAME CONFERENCE TABLE

## PARTS LIST

- 36" SHARED LEG (1)
- 30" END LEG (2)
- FLAT BRACKET (2)
- SURFACE FASTENERS (2)
- BISCUITS (2)
- END SECTION TOP (2)

## REQUIRED TOOLS

- DRILL & PHILLIPS HEAD BIT
- ALLEN WRENCH
- TAPE MEASURE

### IMPORTANT INFORMATION PRIOR TO ASSEMBLY

ASSEMBLE TABLE ON A CARPETED, SOFT, OR PROTECTED AREA WHERE INSTALLATION WILL OCCUR  
DO NOT DRAG ASSEMBLED TABLE  
2 PEOPLE NEEDED FOR ASSEMBLY. 3 PEOPLE REQUIRED TO TURN TABLE UPRIGHT

## STEP 1

- ASSEMBLE OPEN FRAME LEGS. ATTACH LEG BRACKETS TO LEG FRAME USING FLAT HEAD MACHINE SCREW TO FASTEN. TWO SCREWS PER BRACKET.(IMAGE A)
- USE THE SOCKET HEAD MACHINE SCREWS ON THE SIDE OF THE LEG BRACKET, TIGHTEN. TWO SCREWS PER BRACKET (IMAGE B)
- REPEAT ON THE OPPOSITE SIDE FOR SHARED LEGS
- INSERT GLIDES TO THE BOTTOM OF LEG (IMAGE C)

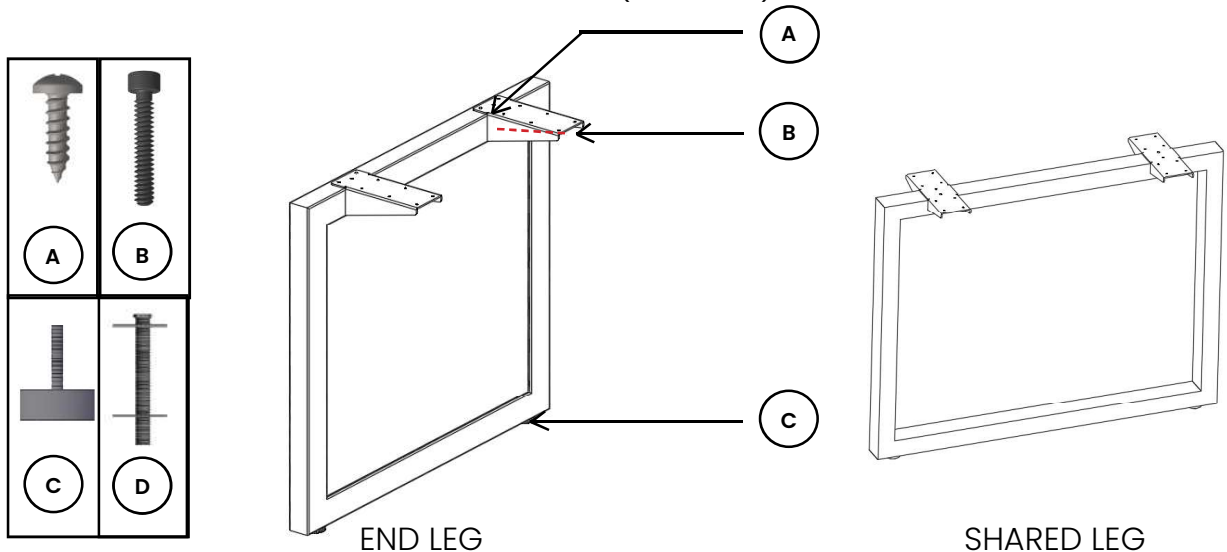

## STEP 2

- LAY TABLE TOPS UPSIDE DOWN CONSECUTIVELY AS SHOWN BELOW IN BOTTOM VIEW REFERENCE. MAKE SURE UNFINISHED EDGES FROM EACH TOP ARE ALIGNED NEXT TO EACH OTHER.
- MEASURE AND POSITION LEGS AS ILLUSTRATED BELOW.
- USING A POWER DRILL, FASTEN THE LEGS ONTO TABLE TOPS BY USING WORK-SURFACES SCREWS
- CONNECT SURFACES WITH FASTENERS (IMAGE D) INTO NOTCHES ON TOPS AND TIGHTEN
- INSTALL FLAT BRACKETS AT SURFACE SEAMS ON TOPS AS SHOWN BELOW

# PIVIT 96" FRAME CONFERENCE TABLE

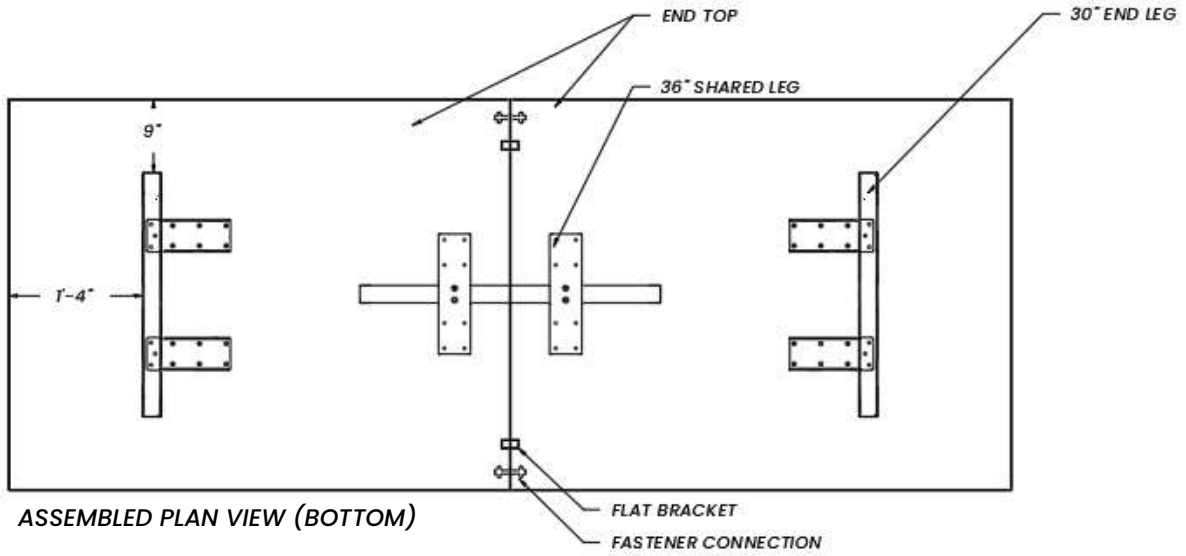

## STEP 3

AFTER ALL COMPONENTS HAVE BEEN FULLY ASSEMBLED AND ATTACHED USE EXTREME CAUTION TO FLIP TABLE RIGHTSIDE UP. 2 OR 3 PEOPLE REQUIRED TO FLIP TABLE.

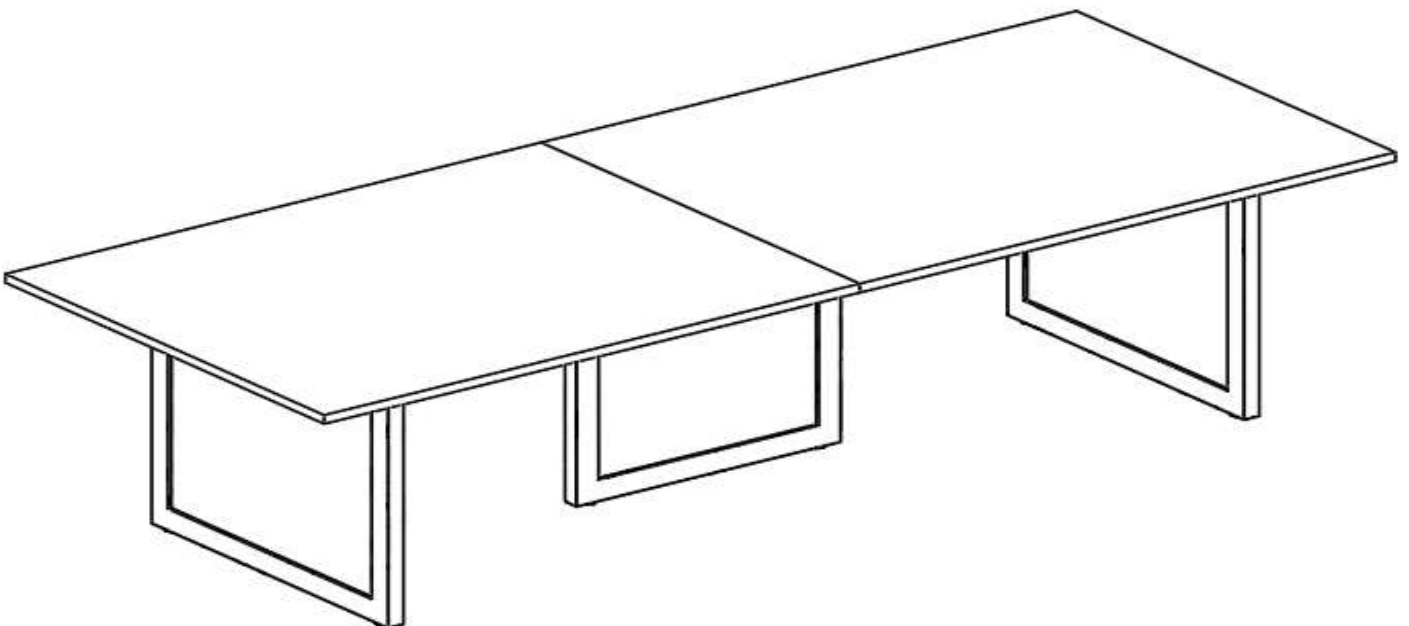

# PIVIT 144" FRAME CONFERENCE TABLE

## PARTS LIST

- 36" SHARED LEG (2)
- 30" END LEG (2)
- FLAT BRACKET (4)
- SURFACE FASTENERS (4)
- BISCUITS (4)
- END SECTION TOP (2)
- MIDDLE SECTION TOP (1)

## REQUIRED TOOLS

- DRILL & PHILLIPS HEAD BIT
- ALLEN WRENCH
- TAPE MEASURE

### IMPORTANT INFORMATION PRIOR TO ASSEMBLY

ASSEMBLE TABLE ON A CARPETED, SOFT, OR PROTECTED AREA WHERE INSTALLTION WILL OCCUR  
DO NOT DRAG ASSEMBLED TABLE

2 PEOPLE NEEDED FOR ASSEMBLY. 3 PEOPLE REQUIRED TO TURN TABLE UPRIGHT

## STEP 1

- ASSEMBLE OPEN FRAME LEGS. ATTACH LEG BRACKETS TO LEG FRAME USING FLAT HEAD MACHINE SCREW TO FASTEN. TWO SCREWS PER BRACKET.(IMAGE A)
- USE THE SOCKET HEAD MACHINE SCREWS ON THE SIDE OF THE LEG BRACKET, TIGHTEN. TWO SCREWS PER BRACKET (IMAGE B)
- REPEAT ON THE OPPOSITE SIDE FOR SHARED LEGS
- INSERT GLIDES TO THE BOTTOM OF LEG (IMAGE C)

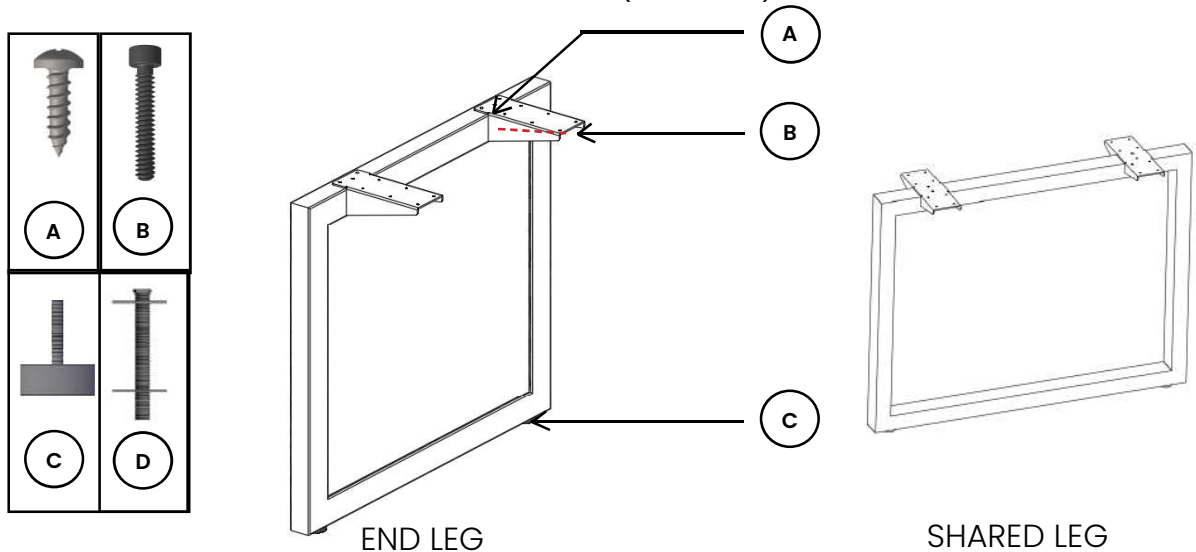

## STEP 2

- LAY TABLE TOPS UPSIDE DOWN CONSECUTIVELY AS SHOWN BELOW IN BOTTOM VIEW REFERENCE. MAKE SURE UNFINISHED EDGES FROM EACH TOP ARE ALIGNED NEXT TO EACHOTHER.
- MEASURE AND POSITION LEGS AS ILLUSTRATED BELOW.
- USING A POWER DRILL, FASTERN THE LEGS ONTO TABLE TOPS BY USING WORKSUR-FACES SCREWS
- CONNECT SURFACES WITH FASTENERS (IMAGE D) INTO NOTCHES ON TOPS AND TIGHTEN
- INSTALL FLAT BRACKETS AT SURFACE SEAMS ON TOPS AS SHOWN BELOW

# PIVIT 144" FRAME CONFERENCE TABLE

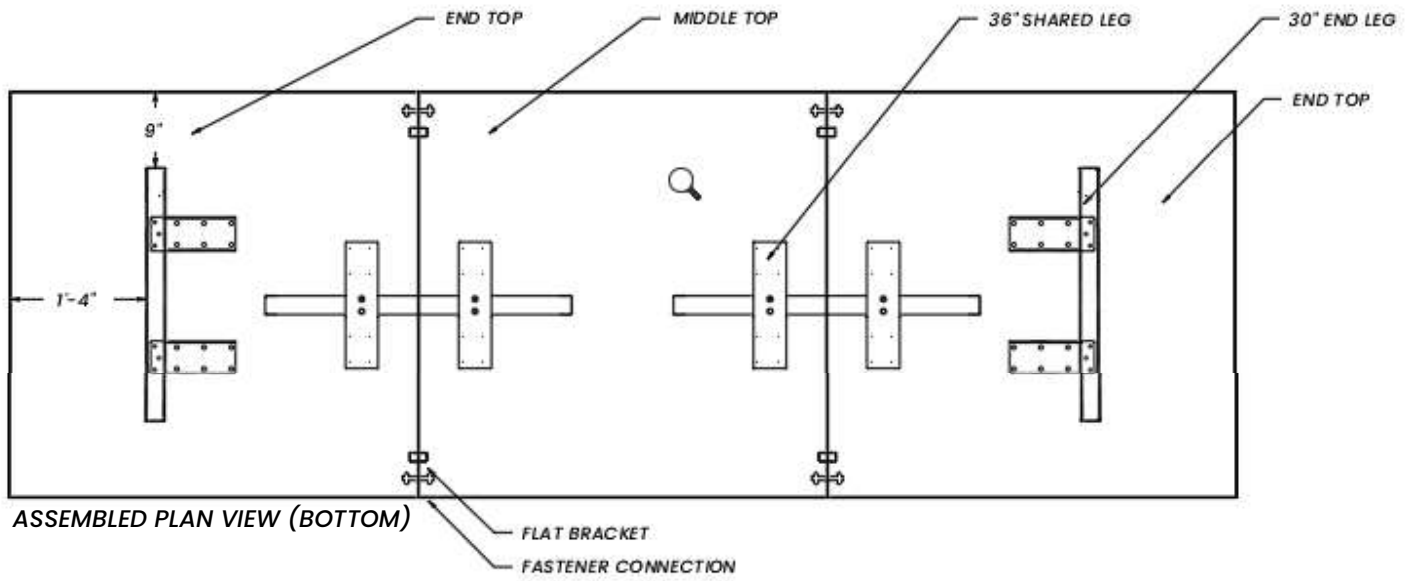

## STEP 3

AFTER ALL COMPONENTS HAVE BEEN FULLY ASSEMBLED AND ATTACHED USE EXTREME CAUTION TO FLIP TABLE RIGHTSIDE UP. 2 OR 3 PEOPLE REQUIRED TO FLIP TABLE.

