

Assembly Instruction For Derby Chair

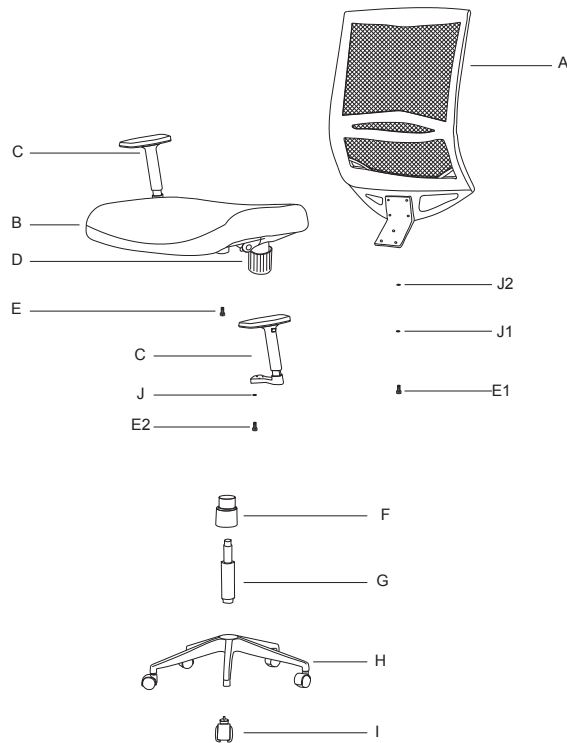

PARTS LIST:

A. BACK CUSHION.....	1 PC
B. SEAT CUSHION	1 PC
C. ARM RESTS (LEFT & RIGHT).....	1 PR
D. MECHANISM.....	1 PC
E. SCREWS FOR MECHANISM (1/4"*6/8").....	4 PCS
E1. SCREWS FOR BACK SUPPORT (M8*20MM).....	3 PCS
E2. SCREWS FOR ARMRESTS (1/4" *1-1/8").....	6 PCS
F. GAS LIFT COVER.....	1 PC
G. GAS LIFT.....	1 PC
H. 5-STAR BASE.....	1 PC
I. CASTERS.....	5 PCS
J. Φ15MM WASHER.....	6 PCS
J1. SPRING WASHER.....	3 PCS
J2. Φ19MM WASHER.....	3 PCS

INSTRUCTIONS

- Carefully unpack all parts and identify them with parts list before attempting to assemble
- Attach both LEFT AND RIGHT ARM RESTS (C) to SEAT CUSHION (B) by using 6 SCREWS (E2) with 6 WASHERS(J)
- Attach BACK CUSHION (A) into the gap between MECHANISM (D) and SEAT CUSHION (B), then fix them by using 3 SCREWS (E1) with 3 SPRING WASHER(J1) and 3 WASHER(J2)
- Put 5 CASTERS (I) into the holes on 5-STAR BASE (H)
- Insert the pre-assembled seat unit onto gas lift to finish assembly

NOTES

Remove all wrapping materials, including staples and packing straps before you start to assemble.
Keep all hardware parts out of reach of children.