

HiLo Desk

Assembly Instructions

3-Leg Base

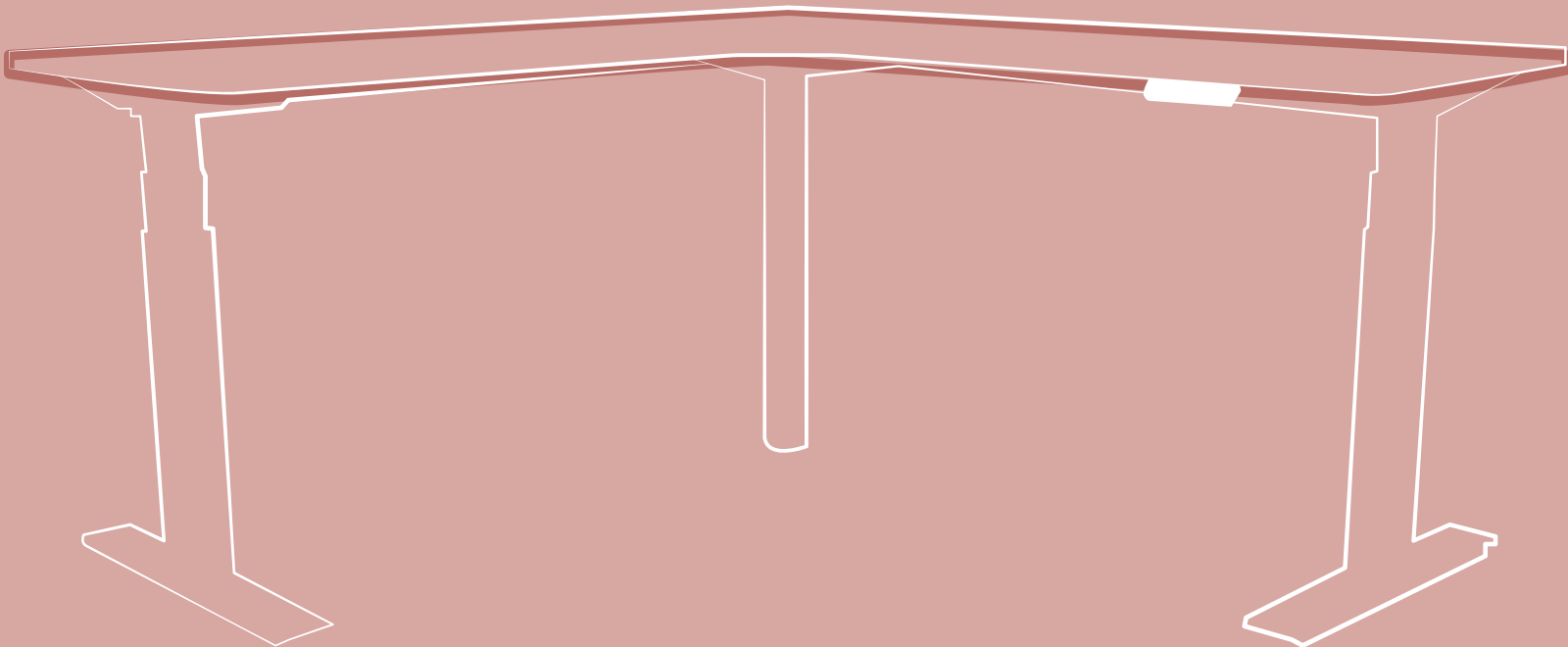

Table of Contents

1. General

- 1.1 Local value of the user manual
- 1.2 Intended use

2. Safety information

- 2.1 Informal safety measures
- 2.2 Use of the adjustable frame
- 2.3 Specific dangers
- 2.4 In an emergency
- 2.5 Maintenance
- 2.6 Cleaning

3. Packaging

- 3.1 Part checklist
- 3.2 Screw checklist

4. Assembly

- 4.1 Assembly step by step
- 4.2 Torque guide

5. Operating instructions

- 5.1 Zero setting
- 5.2 General operation
- 5.3 Container and shelf stop position
- 5.4 Change the displayed desktop position (cm or inch)
- 5.5 Saving a desktop position
- 5.6 Adjusting the desktop to a saved position
- 5.7 Reset control unit to factory settings
- 5.8 Changing the desktop height displayed

6. Programmable remote control operating instructions

- 6.1 Enter the setting menu
- 6.2 Change the displayed desktop position (cm or inch)
- 6.3 Intelligent system protection for desktop move up
- 6.4 Intelligent system protection for desktop move down
- 6.5 Changing the desktop height displayed
- 6.6 Lock or unlock the programmable remote control

7. Troubleshooting

- 7.1 Possible faults and remedies
- 7.2 Error messages and error codes

General

1.1 Local value of the user manual

The guiding principle for safe use and trouble-free operation of this adjustable frame is the knowledge of basic safety information and regulations. This user manual includes the most important information needed for assembling and operating the adjustable frame safely. More importantly, the safety information about the adjustable frame must be observed at all times.

1.2 Intended use

The adjustable frame must be used only as a workstation for sitting / standing within the office environment or other indoor areas. Please observe the provision of section 2, Safety Information. Children may be unaware of the dangers caused by the adjustable frame if unsupervised. Any other use except the above should be considered improper. The manufacturer can in no way be held liable for damage arising from improper use.



Any changes or modification not expressly approved by the manufacturer could void the user's authority to operate the equipment.

Safety Information

When installing and using electrical equipment, basic safety precaution should always be followed to avoid a risk of fire, electric shock, or injury to persons.

2.1 Informal safety measures

- Keep the user manual in the place where the adjustable frame is used at all times.
- Keep children away from the appliance when operation.

2.2 Use of the adjustable frame

- When adjusting upwards and downwards, make sure that no persons or items will collide with the frame.
- Don't use the adjustable frame on an uneven surface, or it will not be steady.
- Never exceed the maximum load capacity on the adjustable frame. Please check the load capacity in Section 7, Specification.
- The control unit is only used for specified linear actuator, don't use appliances not recommended by the manufacturer.

2.3 Specific Dangers

- When assembling and operating the adjustable frame, make sure there is enough space to avoid collisions in all available directions.
- Don't pull, push or lift the frame if operating. Make sure to avoid twisting the legs.
- Insert the plug only into a proper socket. If it does not fit, contact a qualified electrician to install the proper outlet. Don't change the plug in any way.
- Be aware that the control box can only be connected to the voltage printed on the label.

2.4 In an emergency

- Stop using the adjustable frame immediately if you notice anything unusual (strange sounds etc.).
- The frame should be repaired by professional staff. Stop using the adjustable frame until it has been successfully repaired.
- Any other emergencies please contact customer services.

2.5 Maintenance

- The adjustable frame and its components are low-maintenance items and need no special regular maintenance.
- Any broken components removed must be replaced with new, original components made by the manufacturer.
- Don't alter the construction of the adjustable frame.

2.6 Cleaning

- Clean the frame once a week with a dry cloth.
- Clean the frame with a damp cloth and a weak solution of cleaner once every two weeks.

HiLo 3-Leg Base

Packaging

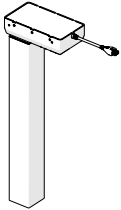

Leg (3 Pcs)

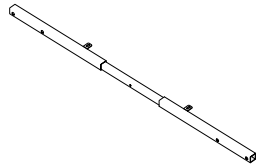

Frame (4 Pcs)

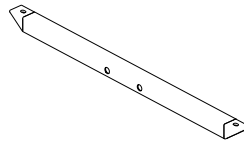

End Pipe (2 Pcs)

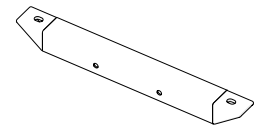

3rd Leg End Pipe(1 Pcs)

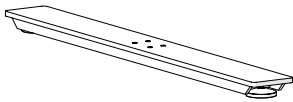

Feet (2 Pcs)

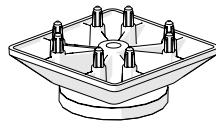

Adjustment Feet(1 Pcs)

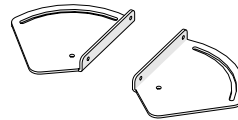

3rd Leg Bracket(1 Set)

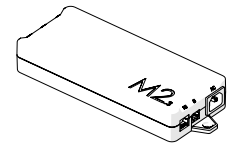

Control Unit (1 Pcs)

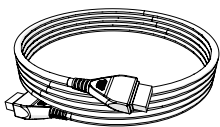

Connection Cable (3 Pcs)

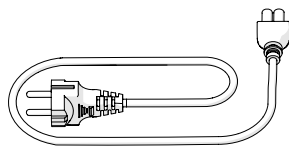

Power Cable (1 Pcs)

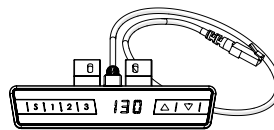

Remote Control (1 Pcs)

Parts displayed above may vary,
based upon frame configuration

HiLo 3-Leg Base

Packaging

Screw Checklist

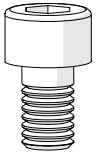

M6x12 (18 Pcs)

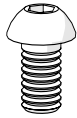

M8X12 (4 Pcs)

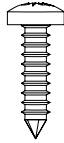

ST 4.8x19 (16 Pcs)

Matching Screw

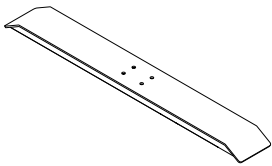

Steel Foot

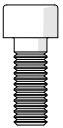

M6x16 (8pcs)

Parts displayed above may vary,
based upon frame configuration

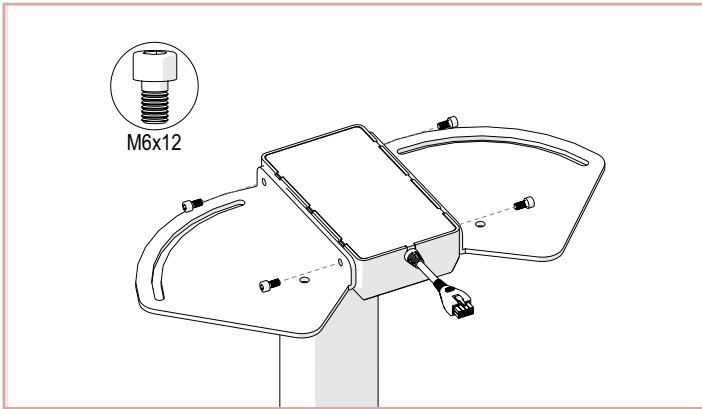

Step 1
Assemble the middle Leg and Bracket as illustrated above. Please refer to **Torque Guide**.

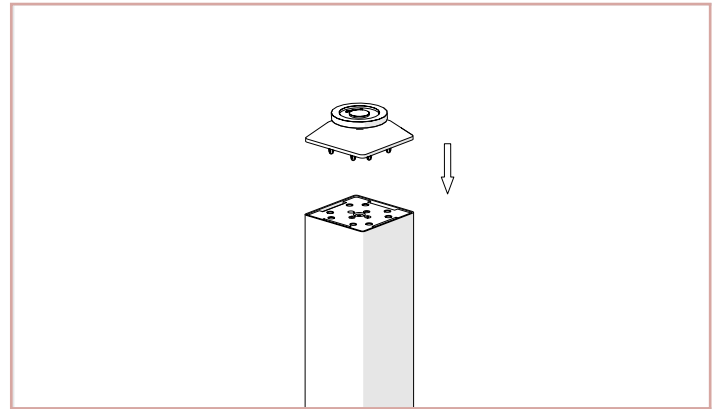

Step 2
Mount the Adjustment Feet to the middle Leg as illustrated above. Please punch in, do not use a hammer.

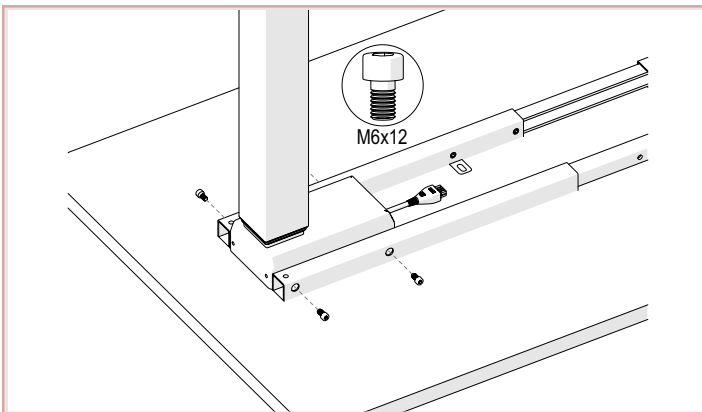

Step 3
Assemble the Top Frame and Leg as illustrated above. Please refer to **Torque Guide**.

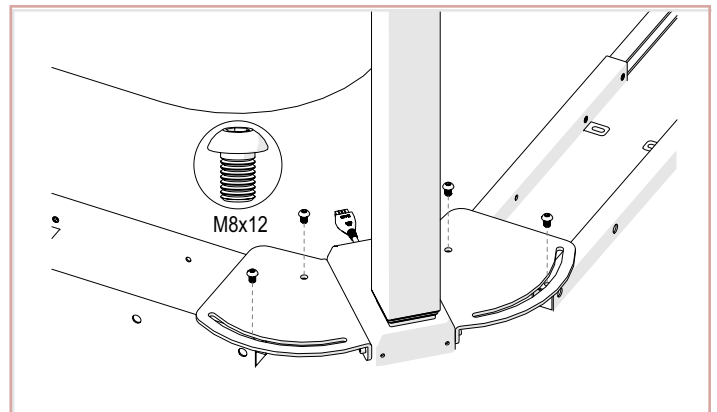

Step 4
Assemble the middle Leg and 3rd Leg Bracket as illustrated above. Please refer to **Torque Guide**.

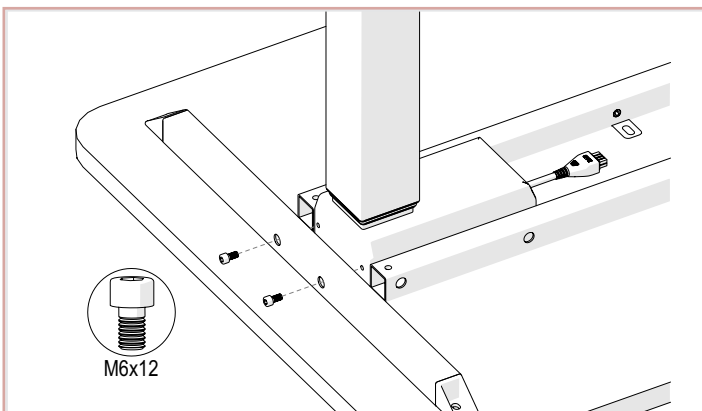

Step 5
Assemble the Leg and End Pipe for both left and right side as illustrated above. Please refer to **Torque Guide**.

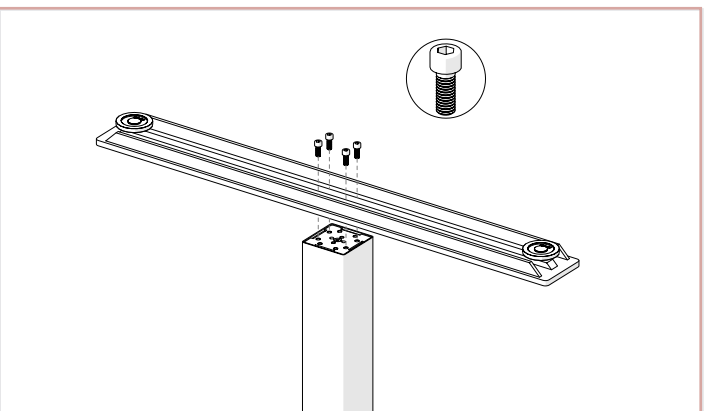

Step 6
Mount the Feet as illustrated above. The smooth side of the plate faces the foot. Please refer to **Screw Part List** Select the appropriate feet and the matching screw. Please refer to **Torque Guide**.

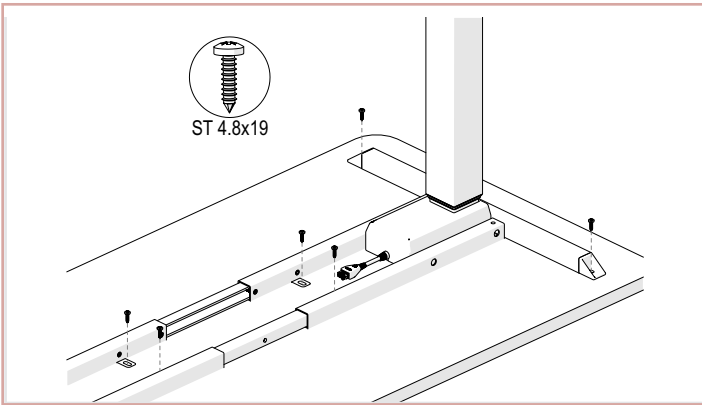

Step 7
Mount the Frame to the Table top and fix the Top Frame as illustrated above. Please refer to **Torque Guide**.

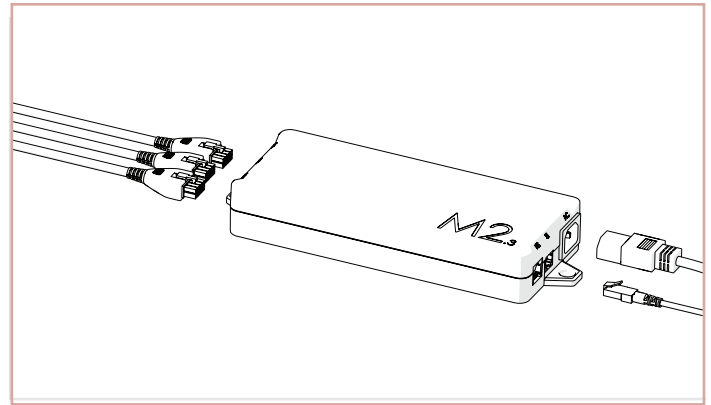

Step 8
Connect the Motor Cable to the Control Unit as illustrated above.
⚠ Do not put power to the system before it is fully assembled.

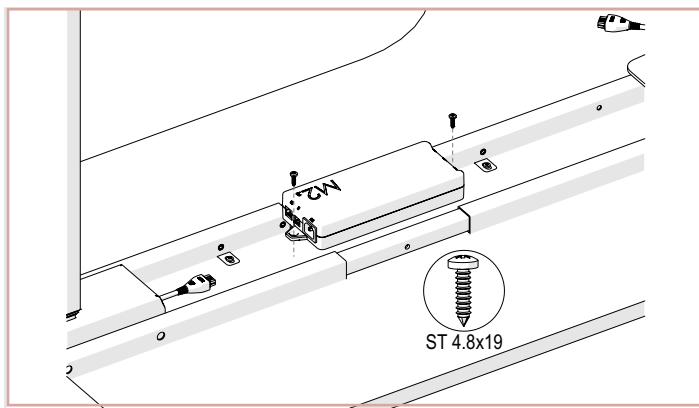

Step 9
Mount the Control Unit as illustrated above. Please refer to **Torque Guide**.

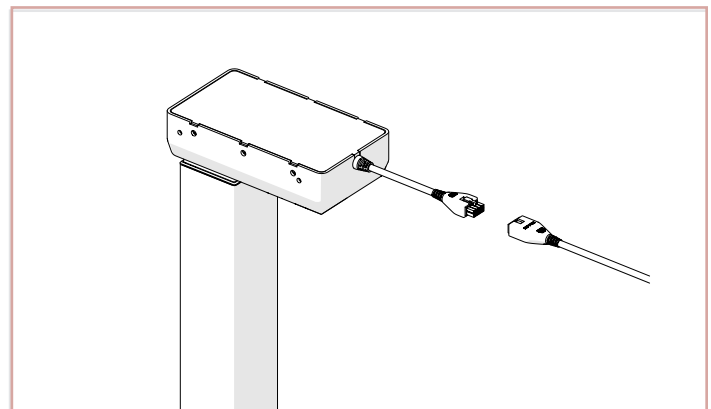

Step 10
Connect the Motor Cable to the Leg as illustrated above.

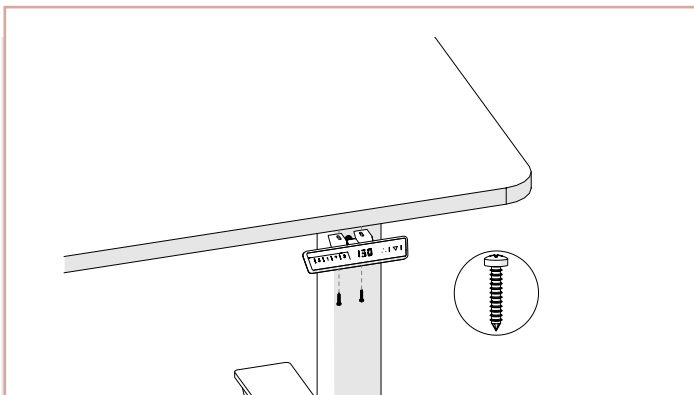

Step 11
Mount the Remote Control to the Table top as illustrated above. Please refer to **Screw Part List** Select the appropriate feet and the matching screw. Please refer to **Torque Guide**.

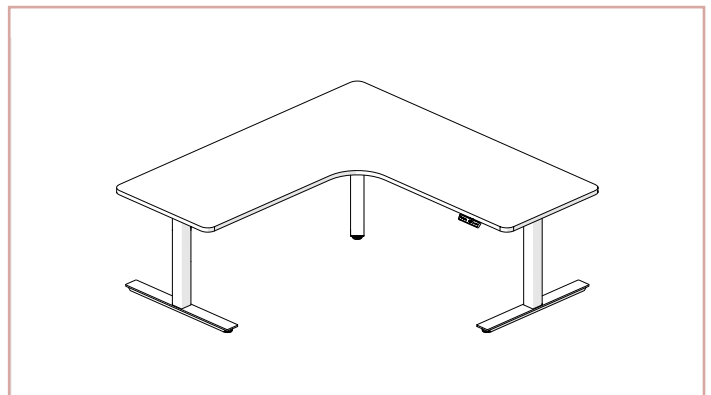

Step 12
Perform Zero Setting.

Packaging

Remote Control

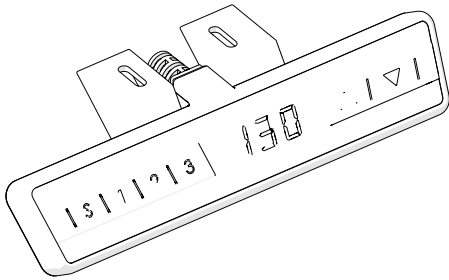

Matching Screw

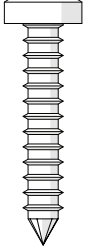

ST 2.9x16

Before attempting assembly of the Height Adjustable Frame, please read safety information in Section 2.



Torque Guide

- M6 Screw's max torque = 6nm
- M8 Screw's max torque = 6nm
- Tapping screws hand tightening only

- S Setting Button
- 1 Memory Position 1
- 2 Memory Position 2
- 3 Memory Position 3
- ▲ Up
- ▼ Down

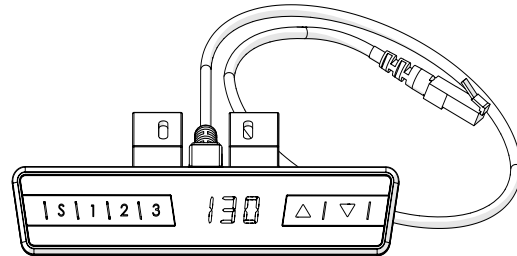

5.1 Zero Setting:

When using the height adjustable frame for the first time lower the desk to the lowest height as explained below before proceeding .

- Press ▼ button and keep pressing the button until the desktop has reached the lowest position (programmed desktop position).
- Press ▼ button again and hold. After about five seconds, the desktop will slowly move further down until it reaches the lowest possible desktop position.
- Release ▼ button. The electric height adjustable frame is now ready for use.



Zero setting position is approximate 5mm lower than original starting height position.

5.2 General Operation:

This function enables you to adjust the frame upwards or downwards.

Press ▲ or ▼ button and keep pressing the button until the required frame height is reached.



The frame will continue moving upwards or downwards until you release the button or the maximum / minimum height is reached.

5.3 Container and Shelf Stop position:

These two features can be used to limit the movement area of the desktop (e.g. if a container is placed underneath the desktop). A container stop position can be defined in the lower half of the movement area, a shelf stop position in the upper half. If a container stop position is set this position will be the lower limit position. If a shelf stop position is set, this position will be the new upper limit position.

To store a container stop / shelf stop position, go on as shown below:

- Move the frame to the position where the container stop / shelf stop position shall be stored. Do so by pressing the ▼ or ▲ until you reach the desired position.
- Press both up and down button (▲ & ▼) for 10 seconds. The control unit will click twice when the container stop / shelf stop position is stored.



A container stop position can only be stored in the lower half of the movement area and a shelf stop in the upper half. These steps have to be done for a container stop and a shelf stop position separately!

To remove the container stop/ shelf stop position follow the instructions below:

- Move the frame to any position in the lower half to deactivate the container stop. Move the frame to any position in the upper half to deactivate the shelf stop. Do so by pressing the ▲ or ▼ button until you reach the desired position.
- Press both up and down button (▲ & ▼) for 10 seconds. The control unit will click once when the container stop / shelf stop position is deactivated.



These steps have to be done for a container stop and a shelf stop position separately!

5.4 Saving a desktop position:

This function allows you to save a defined desktop height. One desktop height can be saved per memory position key. To save a position follow the instructions below:

- Adjust the desktop to the desired desktop position you would like to save. The display will show the desktop height (e.g. 73cm).
- Press the Setting button (S). The display will read S --.
- Press the desired memory position button (e.g. 2). The display will read S 2.
- The set desktop position will now be saved to the selected memory position button.



When turning on the ZGO Control Unit for the first time, all saved positions are set to the lowest desktop height (minimum desktop position).

5.5 Adjusting the desktop to a saved position:

You can use this function to adjust the desktop to a saved height.

To change to a saved position, follow the instructions below:

- Press the desired memory position button (e.g. 2) and hold it down. The desktop will move until it reaches the saved position.
- If you release the key before the saved position is reached the desktop will stop and the saved desktop position will not be reached.
- The desktop has reached the saved position. Now release the memory position button. The display will read the current (saved) desktop position.



The following actions should only be performed by properly trained personnel.

6.1 Enter the setting menu

Follow the instructions below to enter the setting menu to change the settings for the control unit.

- Press the “S” button five seconds. The display will read “S-X”.
- The display will start flashing.
- Pressing up or down button (▲ & ▼) to choose which parameter to change.
- Press the “S” button to enter the setting.

6.2 Change the displayed desktop position (cm or inch)

Follow the instructions below to change the displayed desktop position from centimeters to inches or the other way around. desktop position itself is not affected by this function.

- Within the setting menu choose “S-1”.
- Press the “S” button to enter the setup menu.
- Press the up or down button (▲ & ▼) to choose the desired setting. “0” means display with “cm” while “1” means display with “inch”.
- Press the “S” button to finish the setup.

6.3 Intelligent system protection for desktop move up

Follow the instructions below to change the sensitivity of the intelligent system protection for desktop move up.

- Within the setting menu choose “S-3”.
- Press the “S” button to enter the setup menu.
- Press the up or down button (▲ & ▼) to choose the desired setting. “0” means ISP close, “1” means ISP least sensitive, “8” means ISP most sensitive.
- Press the “S” button to finish the setup.

6.4 Intelligent system protection for desktop move down

Follow the instructions below to change the sensitivity of the intelligent system protection for desktop move up.

- Within the setting menu choose “S-4”.
- Press the “S” button to enter the setup menu.
- Press the up or down button (▲ & ▼) to choose the desired setting. “0” means ISP close, “1” means ISP least sensitive, “8” means ISP most sensitive.
- Press the “S” button to finish the setup.

6.5 Changing the desktop height displayed

Follow the instructions below to change the height shown on the display but not the actual position of the desktop.

- Within the setting menu choose “S-5”.
- Press the “S” button to enter the setup menu.
- Press the up or down button (▲ & ▼) to adjust the number for the height shown on the display.
- Press the “S” button to finish the setup.

6.6 Lock or unlock the programmable remote control

Follow the instruction below to lock or unlock the programmable remote control.

- Press the “S” button and down button (▼) and hold for five seconds.
- The display will show “Loc” which means the remote control is now locked.
- Press the “S” and up button (▲) and hold for five seconds.
- The display will show the height which means the remote control is now unlocked.

6.7 Reset control unit to factory settings

Follow the instructions below to use a configured control unit on another identical electric height adjustable control unit to its original factory settings.

- Press the up and down button (▲ & ▼) and hold for ten seconds.
- The control unit will “bi” and flash “000”.
- Press the down button (▼) until the display shows the height of the desktop. The control unit has now been reset to the original factory settings.



If one or more motors are changed in a system, the control box must be reset to factory settings and a manual reset has to be performed!

Troubleshooting

In this section you will find detailed information on the following topics:

- Possible faults and remedies
- Error messages on the remote control display

7.1 Possible faults and remedies

Legs not working

Possible Cause

- ≡ Power Cable is not connected
- ≡ Legs are not connected
- ≡ Poor plug contact
- ≡ Control Unit is defective
- ≡ Remote Control is defective

Remedy

- ≡ Plug the Power Cable into the Control Unit
- ≡ Plug the Motor Cables into the Control Unit and Legs
- ≡ Check all connections
- ≡ Replace the Control Unit
- ≡ Replace the Remote Control

Legs only operating in one direction

Possible Cause

- ≡ Mains power breakdown or main power is plugged off during movement
- ≡ Control Unit is defective
- ≡ Remote Control is defective
- ≡ Leg is defective

Remedy

- ≡ Zero setting (if movement is only possible downwards)
- ≡ Replace Control Unit
- ≡ Replace the Remote Control
- ≡ Replace the Leg

Control Unit or Remote Control is not working

Possible Cause

- ≡ Power Cable is not connected
- ≡ Remote Control is not connected
- ≡ Control Unit is defective
- ≡ Power Cable is defective
- ≡ Remote Control is defective
- ≡ Poor plug contact
- ≡ Exposed to liquids

Remedy

- ≡ Plug the power cable into the control unit
- ≡ Plug in the remote control
- ≡ Replace the Control Unit
- ≡ Replace the Power Cable
- ≡ Replace the remote control
- ≡ Check all connections
- ≡ Replace the remote control

Error Messages and Error Codes

7.2 Error messages & Error code (Only on external remote with display)

The display reads **HOT**.

Possible Cause

- ≡ The control unit is fitted with overheating protection. Overheating has caused it to stop the control unit

Remedy

- ≡ Wait until the control unit has cooled down and **HOT** is no longer displayed. The SMART-SPFE control unit is then operational again

The display reads **E + an error code**

NOTE: (If different error code than shown below, contact customer service)

Possible Cause

- ≡ There is an internal fault in the control unit

Remedy

- ≡ Proceed as indicated in the following list

Error code Note		How to handle it
E01	≡ The main supply voltage is over 45V	Check the main power supply
E02	≡ The height deviation between the screws exceeds 1cm	Re-initialize
E04	≡ Remote control connecting or communication error	Check the remote control cable
- - -	≡ In the event of a drag-stop display	Release the button and run again
E06	≡ Main power start did not succeed, lower than 20V	Replace the main power supply, or check the main power cable
E07	≡ Protect when the main power supply is running, lower than 20V	Power up again
E08	≡ Tilt when the desktop is running	Re-initialize
HOT	≡ High power supply temperature, or run over 2 minutes in 18 minutes	Wait for the power temperature to drop and rerun
E11	≡ Motor 1 not connected	Check the cable
E12	≡ Motor 1 Error in current sampling channel	Replace the control panel
E13	≡ Motor 1 missing phase, phase line disconnect	Check if the motor is not properly connected to the line
E14	≡ Motor 1 hall error, or hall line disconnect	Check the hall signal, or replace the cable
E15	≡ Motor 1 internal short circuit	Replacing the motor
E16	≡ Motor 1 locked-rotor	Re-initialize

If the mains power supply is lost or becomes disconnected from the control unit during movement of the drives, zero setting might be necessary.

Error code Note		How to handle it
E17	≡ Motor 1 wrong direction of operation	Switch the motor line or hall line
E18	≡ Motor 1 overload	Reduce load
E21	≡ Motor 2 not connect	Check the cable
E22	≡ Motor 2 error in current sampling channel	Replace the control panel
E23	≡ Motor 2 missing phase, phase line disconnect	Check if the motor is not properly connected to the line
E24	≡ Motor 2 hall error, or hall line disconnect	Check the hall signal, or replace the cable
E25	≡ Motor 2 internal short circuit	Replacing the motor
E26	≡ Motor 2 locked-rotor	Re-initialize
E27	≡ Motor 2 wrong direction of operation	Switch the motor line or hall line
E28	≡ Motor 2 overload	Reduce load
E31	≡ Motor 3 not connect	Check the cable
E32	≡ Motor 3 error in current sampling channel	Replace the control panel
E33	≡ Motor 3 missing phase, phase line disconnect	Check if the motor is not properly connected to the line
E34	≡ Motor 3 hall error, or hall line disconnect	Check the hall signal, or replace the cable
E35	≡ Motor 3 internal short circuit	Replacing the motor
E36	≡ Motor 3 locked-rotor	Re-initialize
E37	≡ Motor 3 wrong direction of operation	Switch the motor line or hall line
E38	≡ Motor 3 overload	Reduce load
E40	≡ Controller drop line in series	Check the cable
E41	≡ Error in the series signal	Check the cable, or replace the controller

Questions?

Please contact us at
www.compeloffice.com/customer-support
 for assistance.

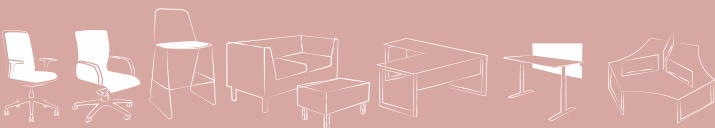

compel® for your whole workspace

compeloffice.com | 773.253.4758