



2-Stage Base

Operation Information

INITIALIZATION/RESET

The desk must be initialized/reset after any of the following:

- After assembly
- After disconnection from the power supply
- After any impact on the table top.

To initialize/reset, move the table to the lowest position by pressing the DOWN button on the handswitch until the columns reach the lowest position. Press the DOWN button again until the table moves slightly down to the machine zero point and back up to the operation zero point. Release the DOWN button. If the button is released too soon, the table legs will not move up. Repeat the reset process. The control box is programmed with a parameter file which controls the table legs' lower and upper travel limits. Under no circumstance should a control box from one table be moved to another.

NORMAL HANDSWITCH OPERATION (for all handswitch types)

By pressing the UP or DOWN buttons, the table will move up or down to the desired position. Once the desired position is reached, let go of the UP or DOWN button. The table legs will stop once they reach the lower or upper height limits.

PROGRAMMABLE HANDSWITCH OPERATION (optional)

This programmable handswitch is equipped with a display for showing the current table height in centimeters or inches. The handswitch also will display an error code if an error is detected by the control box. When an error is detected, the display
r e n t t a b l e h e i g h t . T o r e s o l v e t h e e r r o r , s e e t h e T r o u b l e s h o o t i n g S e c t i o n . T h e p r o g r a m m a b l e
h a n d s w i t c h a l s o h a s t h e a b i l i t y t o s a v e u p t o f o u r d i f f e r e n t h e i g h t p o s i t i o n s .

HiLo Assembly Instructions



2-Stage Base

Operation Information

PROGRAMMABLE HANDSWITCH OPERATION (continued)

CHANGE THE HEIGHT UNIT (inches or centimeters)

The handswitch can display the table height in either centimeters or inches. With the help of the S5-menus, the unit of measure can be changed. To change the unit of measure:

1. Press and hold the 1, 2, and UP buttons until the display shows “S 5”.
2. Confirm by pressing the “S” button. Now the display will have changed. To exit the menu without making a selection, wait until the height display appears again.

CHANGE THE HEIGHT DISPLAY

If the displayed value does not match the actual height of the table top, the display can be corrected as follows:

1. Press and release the “S” button.
2. Press and hold the DOWN button until the display starts to flash.
3. Change the height shown on the handswitch by pressing the UP or DOWN button to the desired height. Confirm by pressing the “S” button. To exit the menu without making a selection, wait until the height display appears again.

SAVE MEMORY POSITION

1. Move the table up or down to the desired height.
2. Press the “S” button (in the display “S -” is shown.)
3. Select a position by pressing one of the four number buttons, 1-4, (the display will show the setting as “S1”).
4. The saved position is confirmed by a double click sound from the control box. The display shows the current table height. Repeat steps to save a maximum of four different positions.

RECALL MEMORY POSITION

Press and hold the desired memory button (1, 2, 3 or 4) the table moves from the current position into the saved position. The button must be pressed until the position is reached. If the button is released, the table will stop short of the desired height.

HiLo Assembly Instructions



2-Stage Base

Troubleshooting Guide

ERROR CODE	SOURCE	SOLUTION
Table does not move	No power supply	Plug in the power cord or check the connection on the control box
	No connection or a loose connection to the drives	Verify the plug connections of the motor cable to the control box
	No connection or a loose connection to the handswitch	Verify the plug connections of the motor cable to the control box
	Max lifting capacity is exceeded	Reduce the weight or load on the desktop
	Max time limit is exceeded	Control is activated automatically after approx. 9 minutes
	Defective drive	Contact customer service
	Defective control box	Contact customer service
	Defective handswitch	Replace the handswitch
Table moves down at a slow rate	Control box expects new reset	Reset control box. (See page 18)
During operation, tables moves at a slow rate	Max lifting capacity is exceeded	Reduce weight
Table moves on one side only briefly and then stops	No connection or a loose connection to the drives	Verify the plug connections of the motor cable to the control box and reset the control box
	Defective drive	Contact customer service



Troubleshooting Guide

Handswitch Display

ERROR CODE	SOURCE	SOLUTION
HOT	The control box monitors the duty cycle (time-controlled) and its max temperature. A value has been exceeded.	Wait until the "HOT" display goes out - the table is working properly again
E00	M1 - Internal Fault	Unplug and contact customer service
E01	M2 - Internal Fault	
E02	M3 - Internal Fault	
E12	M1 - Defect	Unplug. Correct the external short circuit and/or verify the cable to the drives. Plug cables into the control box and re-run table.
E13	M2 - Defect	
E14	M3 - Defect	
E24	M1 - Overcurrent	Collision → resolve if necessary
E25	M2 - Overcurrent	Max load exceeded → remove excess load from the table
E26	M3 - Overcurrent	If the problem still exists, please contact customer service
E36	M1 - Not connected	Motor not connected. Check cable / connector to the drive. Reset the table (see page 18).
E37	M2 - Not connected	
E38	M3 - Not connected	
E48	Overcurrent drive 1	Collision → resolve if necessary
E49	Overcurrent drive 2	Max load exceeded → remove excess load from the table
E55	Drive 1 - Synchronization is lost	If necessary, reduce the load on the table
E56	Drive 2 - Synchronization is lost	Reset the table (see page 18)
E60	Collision identified	Option ISP function. Remove source.
E61	Drive replaced	The connection to the drive is interrupted or a new drive is connected. Reset the table (see page 18).

If it is not possible to resolve an error as described, disconnect the power cord, wait a few minutes and reset the table again. If the error still occurs, remove the table from the power source and contact customer service.

HiLo Assembly Instructions



2-Stage Base

Safety Information

IMPORTANT SAFETY INSTRUCTIONS. Save these instructions.

DANGER To reduce the risk of electric shock: Always unplug this furnishing from the electrical outlet before cleaning.

BE CAREFUL WHEN ADJUSTING DESK HEIGHT

Body parts and property can be caught between the moving work surface and an immobile obstacle (such as shelves, furniture, window sills, or walls). Keep at least one inch of clearance around desk and make sure nothing is in table's path for its entire range of motion.

BEFORE RAISING OR LOWERING:

- Check surroundings on all sides of desk are clear
- Make sure corded objects will not be pulled off table or cause other objects to fall
- Make sure desk power cord moves freely as desk moves up and down

DO NOT OVERLOAD DESK

To prevent table from tipping or collapsing, make sure the desk frame is not overloaded by the weight of tabletop and objects on table. Evenly distribute load; excess loads near edges can reduce stability and lead to tip over.

- Do not exceed maximum load (including weight of desktop) of 200 lb. (91Kg) for two-leg configuration,
- Do not exceed edge load of 25 lb. when positioning monitors or mounting accessories.
- Do not sit or stand on table

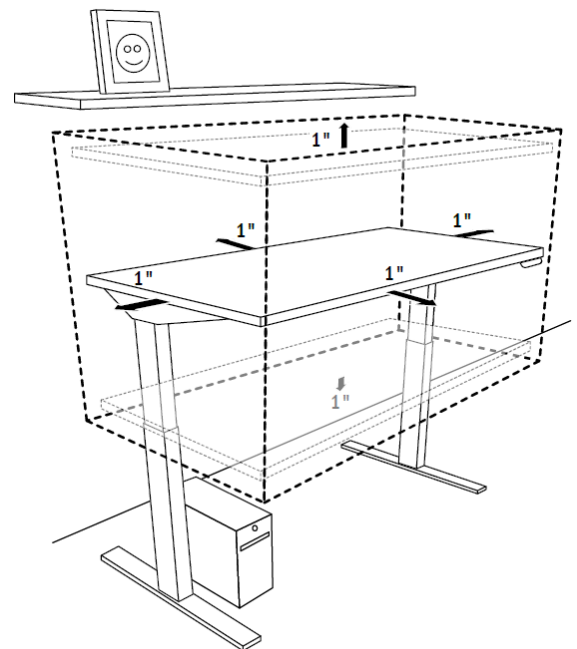

HiLo Assembly Instructions



2-Stage Base

Safety Information

IMPORTANT SAFETY INSTRUCTIONS. Save these instructions.

USE CARE WHEN MOVING DESK

- Clear objects and equipment from table before moving to reduce the risk of tipping over.
- Adjust the desk to its lowest height before moving
- To disconnect, remove plug from outlet
- Do not move a loaded desk

DO NOT OPEN ELECTRICAL COMPONENTS

Do not attempt to service table components. There are no user-serviceable parts inside the motor control units or table legs. If your table needs service, contact customer service. Never operate this workstation if it has a damaged cord or plug.

KEEP TABLE FRAME DRY

Keep all electrical components away from water and high humidity. Clean only with a dry or slightly damp cloth. Do not spray cleaning solutions directly onto table system.

GROUNDING INSTRUCTIONS

This product is equipped with a cord having an equipment-grounding conductor and a grounding plug. Use only the cord provided. Make sure that the product is connected to an outlet having the same configuration as the plug (as shown in Illustration A) that is properly installed and grounded in accordance with all local codes and ordinances. Do not modify the plug provided with the product – if it will not fit the outlet, have a proper outlet installed by a qualified electrician.

No adapters are to be used with this product.

Keep cord away from heated surfaces.

HiLo Assembly Instructions

2-Stage Base



Standards & Certifications

The drive system is tested according to the following standards:

UL 962

Issued: 2014/11/07 Ed: 4 Household and Commercial Furnishings

CSA C22.2#68

Issued: 2009/09/01 Ed: 7 (R2014)

Motor-Operated Appliances (Household and Commercial)

Meets BIFMA X5.5 2014.

