

Mobius Training Table

Assembly Instructions

ASSEMBLE STEP NO.1:

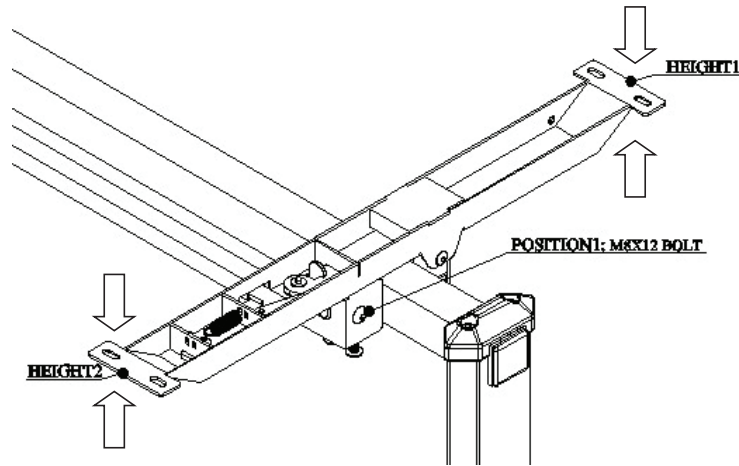

- ① LOOSE POSITION1: M8X12 BOLT,
- ② USE RUBBER HAMMER TO MAKE SURE THAT HERGHT1 AND HERGHT2 ARE IN THE SAME HEIGHT / LEVEL, WITHIN 5MM DIFFERNCE COULD BE ACCEPTABLE.
- ③ THEN TIGHTEN THE SCREWS IN POSITION 1.

ASSEMBLE STEP NO.2:

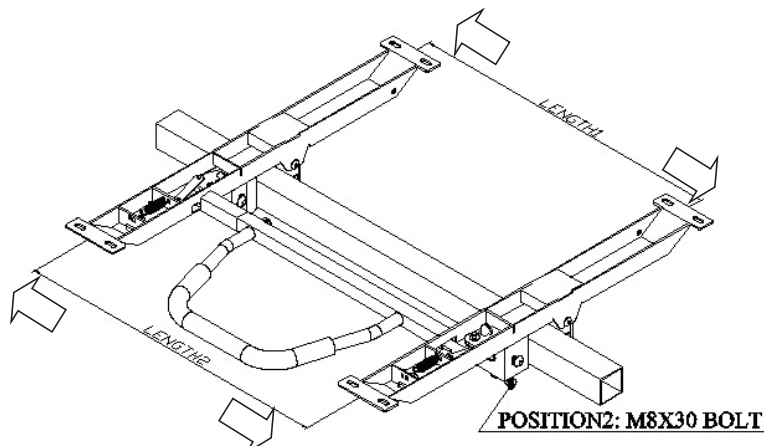

- ① LOOSE POSITION2: M8X30BOLT,
- ② MAKE SURE LENGTH1 AND LENGTH2 HAS SAME DISTANCE , DIFFERENCE WITHIN 5 MM COULD BE ACCEPTABLE.
- ③ AFTER THAT TIGHTEN SCREWS IN POSITION 2.

NOTES

Place all laminated parts on a cleaned and smooth surface such as a rug or carpet to avoid the parts from being scratched.
Check to be sure that you have all parts and hardware.
Remove all wrapping materials, including staples and packing straps before you start to assemble.
Keep all hardware parts out of reach of children.